

Magnetic drive pumps

Withstands difficult operating conditions
and offers high efficiency

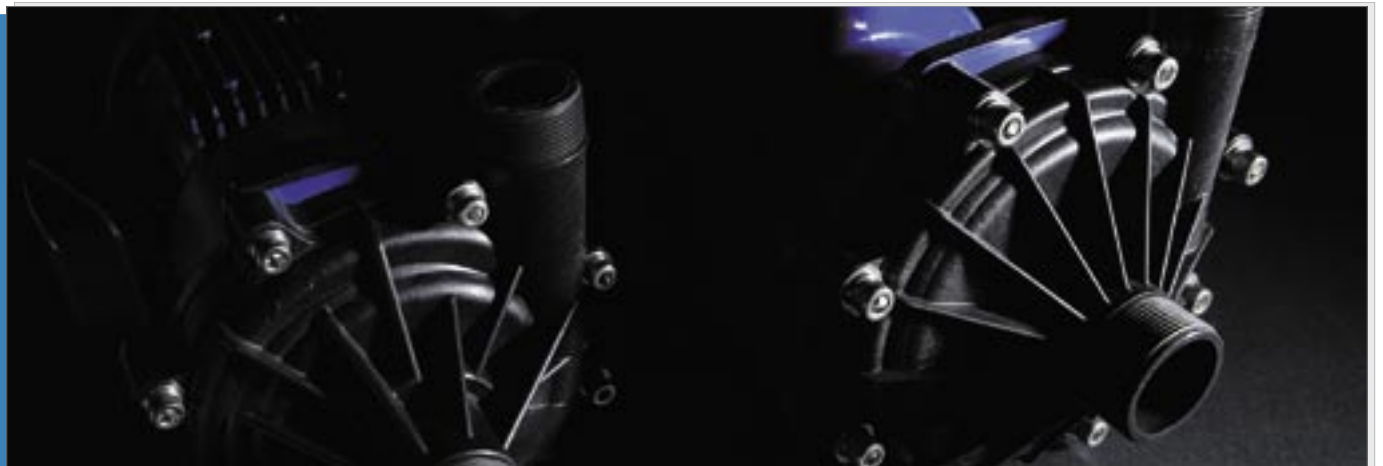

The MX Series represents the latest state of the art design in plastic magnetic drive pumps to meet the most severe of operating conditions.



Withstands difficult operating conditions and offers high efficiency

The MX Series represents the latest state of the art design in plastic magnetic drive pumps to meet the most severe of operating conditions. When fitted with a carbon bearing the MX will allow for brief periods of dry running. The new “self radiating structure” in addition to the existing proven non contact principle and front and rear supported spindle greatly improves the pumps ability to withstand some cavitation and running against closed discharge valve. MX series pumps are highly recommended for use in various production processes such as filtering, spraying, washing and etching in surface treatment processes.

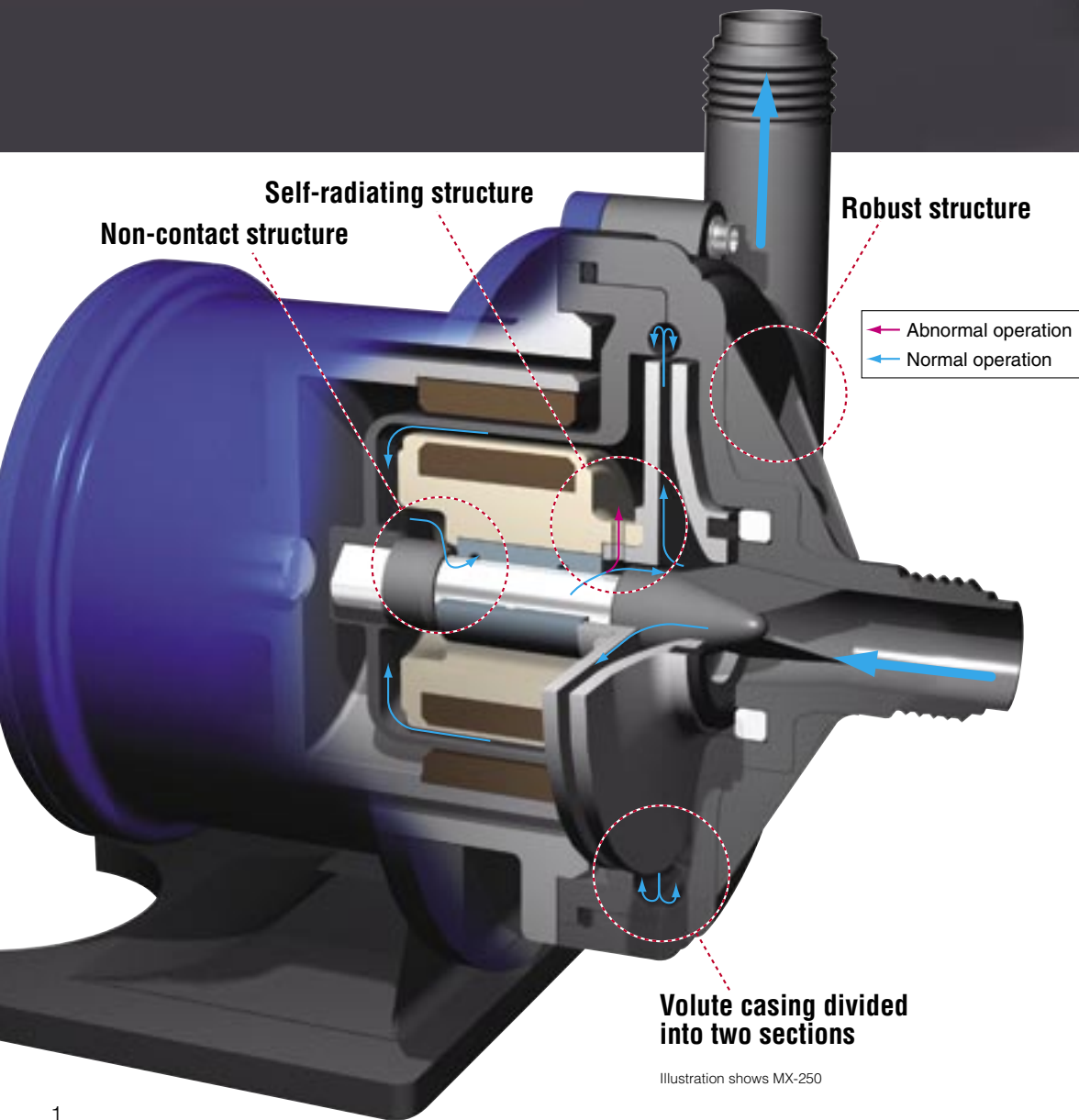

Illustration shows MX-250

- An improved mechanical strength design allows operation under abnormal conditions and results in reduction of running cost and maintenance cost.
- The adoption of a volute casing divided into two raises efficiency.
- Simply constructed, it is robust and facilitates maintenance.



Self-radiating structure

(International patent applied)

Through heat-dispersion holes provided in the fixed portions of the impeller and the magnet capsule, the liquid around the spindle and the bearing is forced to circulate so that heat generated by sliding can be reduced effectively. Thus, thermal deformation and melt are prevented.

(Except MX-70, 100)

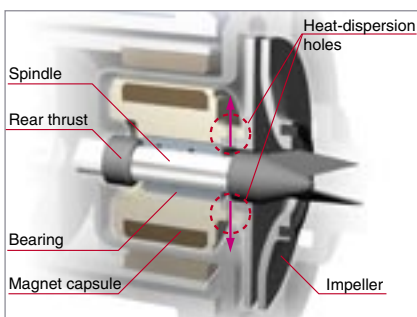

Non-contact structure

By installing the driving magnet and the driven magnet in an inventive way, the movement of the magnet capsule is controlled by magnetic force to prevent the rear thrust and the rear portion of the bearing coming into

contact with each other continuously even during dry running. This structure reduces heat generation and secures lubricant routes.

(Except MX-70, 100)

Volute casing divided into two sections

(International patent applied)

The MX series is the first resin magnet pump which uses the pump casing divided into the front casing and the rear casing to form a vortex chamber as an ideal form. Therefore, the internal leak phenomenon, which means that the liquid getting out of the impeller returns to the pump casing and is suppressed to a minimum and the liquid is efficiently guided to the discharge port to enhance overall efficiency.

(Except MX-400)



Front casing

Rear casing

Robust structure

All stress bearing portions, such as the front and rear casings, are reinforced by means of ribs to improve the pressure resistance and the mechanical strength of the pump.

The bearing is not only fixed by conventional press fit but is also sandwiched between the abutting portion in the depth of the magnet capsule and the rear end of the impeller to improve its reliability under high temperature.

(Except MX-70, 100)

MX-402(H) and 403(H) models: an unplugging preventive lock pin is adopted for ensuring more steady securing.



Front casing of type 100 and 402/403



MX-401

MX-250

Wet end materials

■ MX-70,100

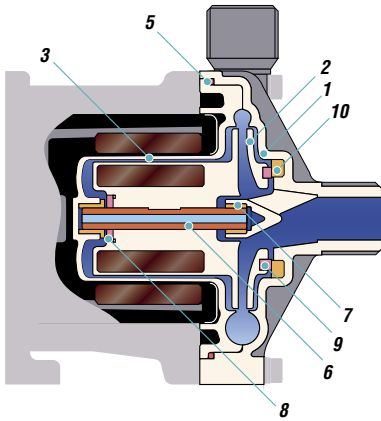

■ MX-250 to 401

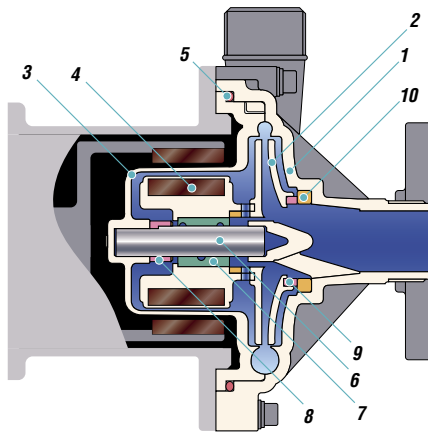

■ MX-402 to 403H

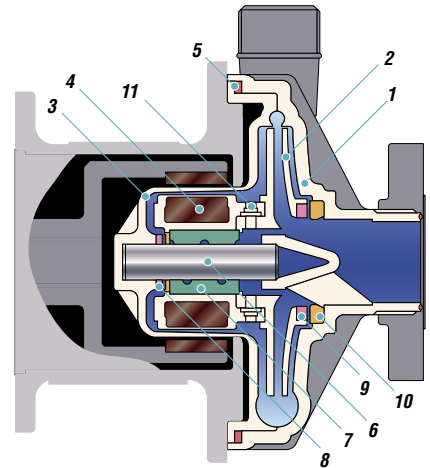

Model	MX-70		MX-100	MX-250 to 403H		MX-250 to 401
Mark	V(E)			CV(CE)	RV(RE)	AV(AE)
1 Front casing	GFRPP				GFRPP	
2 Impeller	CFRPP				GFRPP	
3 Rear casing	GFRPP				GFRPP	
4 Magnet capsule	-				PP	
5 O ring <small>Note 1</small>	FKM(EPDM)				FKM(EPDM)	
6 Spindle	Alumina ceramic				Alumina ceramic	
7 Bearing	CFRPPS		PTFE	Carbon	PTFE	Alumina ceramic
8 Rear thrust	-			CFRPPS (MX-402 to 403H: CFRPEEK)		
9 Mouth ring	-		PTFE	PTFE		
10 Thrust/Liner ring	Alumina ceramic			Alumina ceramic		
11 Lock pin	-			GFRPPS(Only available type 402 to 403H)		-

Note 1: An O-ring made of AFLAS® is also available



MX-403

MX-402

MX-100

Pump identification

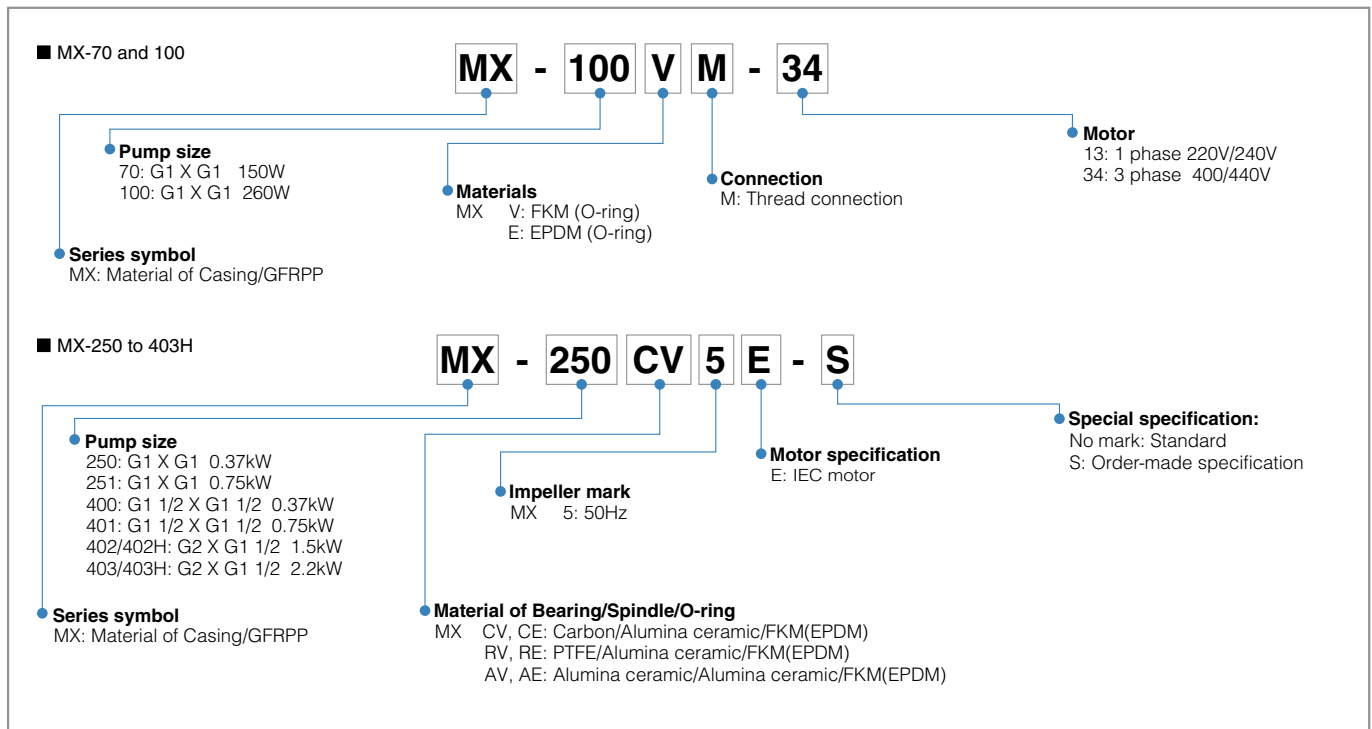

Specifications

50Hz

Model	Connection Suction X Discharge	Limit of S.G. <small>Note 1</small>	Standard capacity L/min - m	Maximum capacity L/min <small>Note 3</small>	Motor kW	Mass kg <small>Note 4</small>
MX-70	G1 x G1 <small>Note 2</small>	1.2	50 - 5.4	90	0.15	6.5
MX-100	G1 x G1 <small>Note 2</small>	1.2	70 - 6	110	0.26	8.2
MX-250	G1 x G1	1.2	50 - 14	150	0.37	7.7
MX-251	G1 x G1	1.0	80 - 19	150	0.75	10.2
MX-400	G1 1/2 x G1 1/2	1.2	100 - 10.5	280	0.37	6.2
MX-401	G1 1/2 x G1 1/2	1.2	150 - 14.5	320	0.75	10.2
MX-402	G2 x G1 1/2	1.2	200 - 20	450	1.5	13.5
MX-402H	G2 x G1 1/2	1.0	100 - 30	160	1.5	13.5
MX-403	G2 x G1 1/2	1.2	250 - 23	520	2.2	14.5
MX-403H	G2 x G1 1/2	1.0	100 - 35	300	2.2	14.5

Note 1) The specific gravity limit values shown above are with maximum discharges. The specific gravity limit varies with the discharge. For details, please contact us.

Note 2) 26mm tube connection option available on the MX-70 and MX-100.

Note 3) AV(AE) type is different in discharge capacity. For details, please contact us.

Note 4) Less motor except MX-70 and 100.

Common specifications

- Range of liquid temperature : 0 to 80°C (10 to 80°C in case AFLAS® O-rings are used.)
- Range of ambient temperature : 0 to 40°C.

Performance curves

50Hz

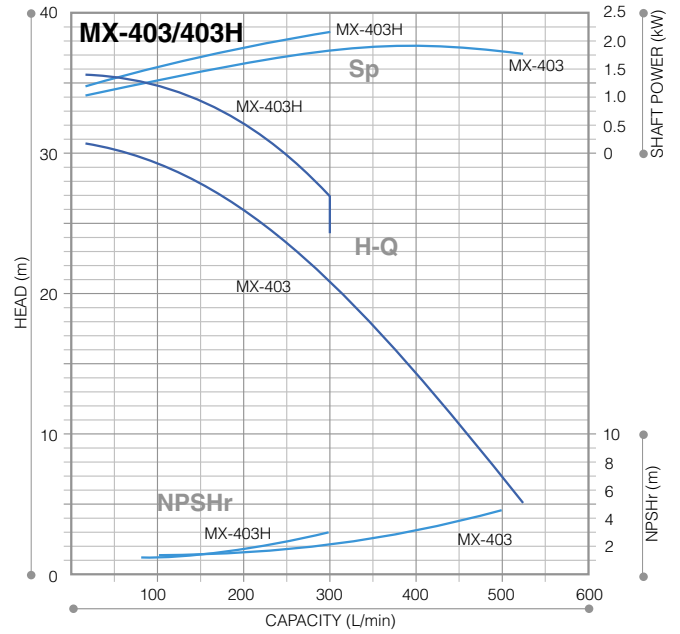
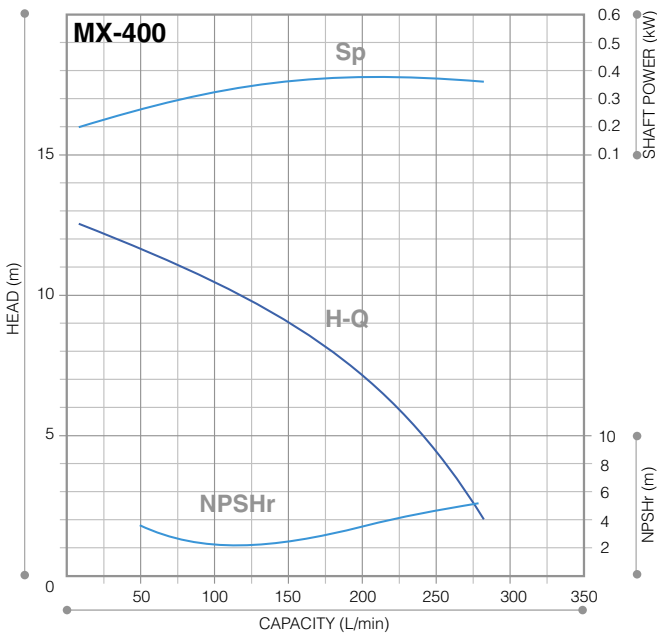
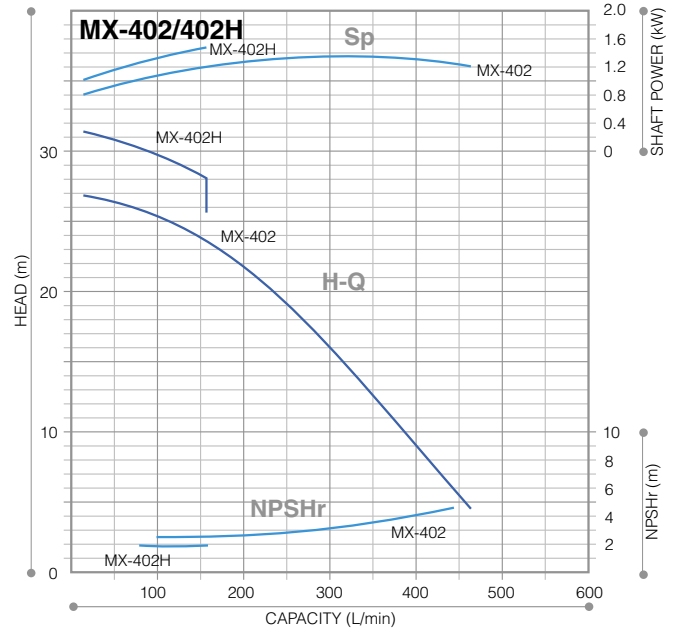
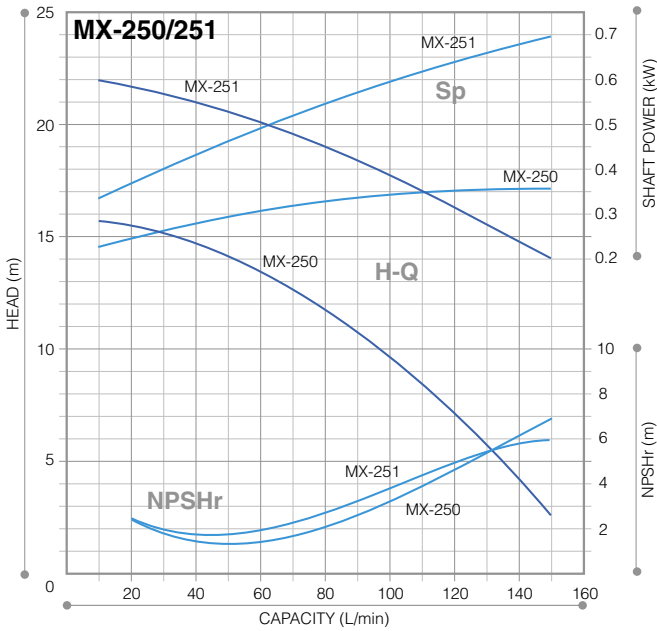
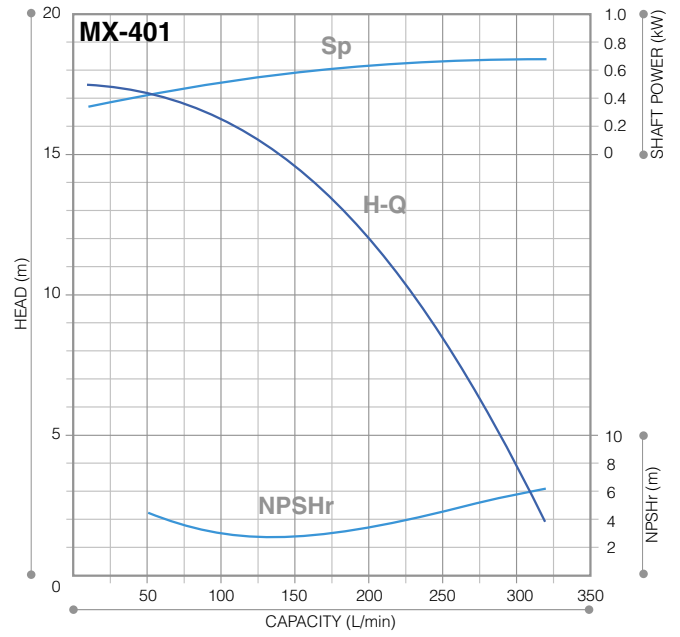
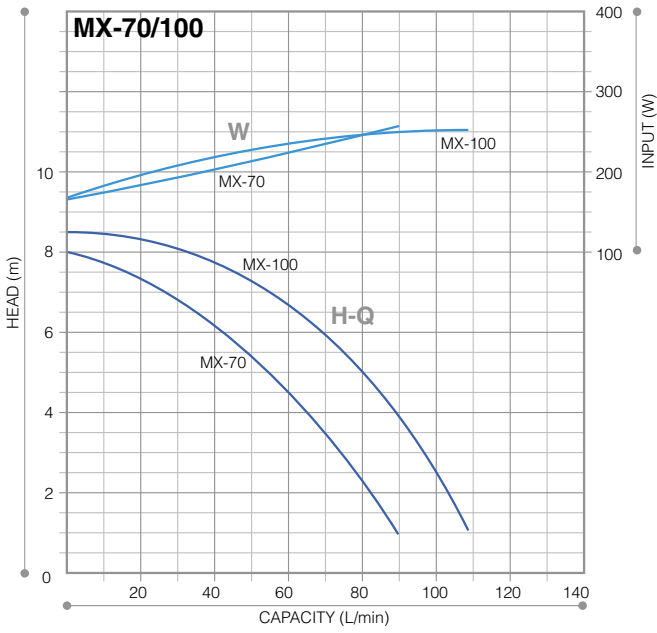

Dimensions

■ MX-70, 100
Note 2

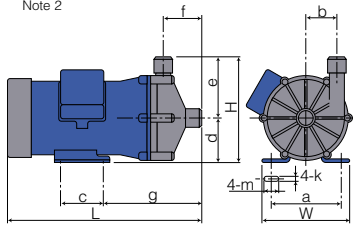

■ MX-250 to 401
Note 1

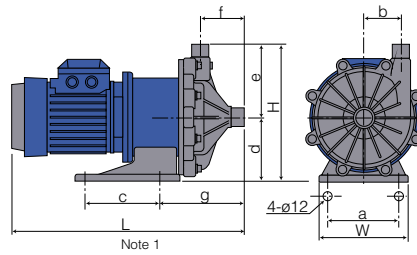

■ MX-402, 402H, 403, 403H
Note 1

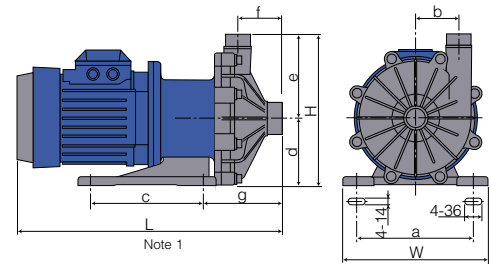

Models	W	H	L	a	b	c	d	e	f	g	k	m
MX-70	130	155	258.5	110	48	40	65	90	53	159.5	7	11
MX-100	150	175	319.5	110	51	70	75	100	65	162	9	27
MX-250	160	247.5	422	130	65	130	115	132.5	82.5	155.5	—	—
MX-251	160	247.5	458.5	130	65	130	115	132.5	82.5	163.5	—	—
MX-400	140	219	423.5	110	54	98	95	124	81	144	—	—
MX-401	160	249	473	130	72	130	115	134	97	178	—	—
MX-402, 402H, 403, 403H	260	274	478.5	208	80	200	120	154	83	151	—	—

Note 1: The dimension may differ with the type of motor installed.

Note 2: MX-70 and MX-100 shows thread type in the above dimensions, Please contact us for tube connection type.

Optional accessories

Iwaki dry running protector DR series

Model DR is electric current sensing type dry running protector. It detects the decreased load current (lower limit) to stop the pump when it runs dry or runs with air sucking in. It can detect over-load, too.



DR-20

- Current figure to be set is indicated on LCD.
- Both top/bottom figures can be set.
Top: Over-load
Bottom: Dry running, air sucking-in operation, operation with suction side closed
- Built-in current transformer
- DIN rail mounting
- It is unable to use DR when inverter is employed in the system.

Specification

50/60Hz

Model	DR-20	
Motor power	380 to 440V three phase	
Applied motor	0.75 to 15kW	
Power control	100 to 240V single phase	
Power	V	200 to 240V ±10% single phase
	Input	3.5W
Detective current	0.5 to 32.0A	
Current transformer(CT)	Built-in	
Outer dimension	D80 X W153 X H122	

Iwaki process magnetic drive pump series

MX-F series

Withstands difficult operating conditions and offers high efficiency

Max. discharge capacity: 510 L/min
Max. discharge head: 30 m
Main materials: CFRETFE



SMX series

Versatile self-priming magnetic drive pump with enhanced durability under abnormal operation

Max. discharge capacity: 280 L/min
Max. head: 17 m
Main materials: GFRPP, CFRETFE



MXM series

Magnetic drive pumps with an excellent balance of features and performance

Max. discharge capacity: 600 L/min
Max. head: 29 m
Main materials: CFRETFE



MDM series

Magnetic drive processing pump with dry running capability

Max. discharge capacity: 1.4 m³/min
Max. head: 72 m
Main materials: CRETFE, PFA

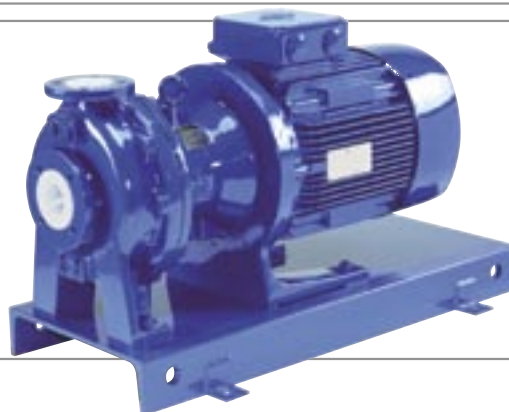

www.iwakipumps.jp

IWAKI CO.,LTD. 6-6 Kanda-Sudacho 2-chome Chiyoda-ku Tokyo 101-8558 Japan TEL : (81)3 3254 2935 FAX : 3 3252 8892

EUROPE / U.S.A.

European office : IWAKI Europe GmbH	TEL: (49)2154 9254 0	FAX: 2154 9254 48
Austria : IWAKI (Austria) GmbH	TEL: (41)26 674 93 00	FAX: 26 674 93 02
Belgium : IWAKI Belgium N.V.	TEL: (32)13 67 02 00	FAX: 13 67 20 30
Denmark : IWAKI Nordic A/S	TEL: (45)48 24 2345	FAX: 48 24 2346
Finland : IWAKI Suomi Oy	TEL: (358)9 2745810	FAX: 9 2742715
France : IWAKI France S.A.	TEL: (33)1 69 63 33 70	FAX: 1 64 49 92 73
Germany : IWAKI Europe GmbH	TEL: (49)2154 9254 50	FAX: 2154 9254 55
Holland : IWAKI Holland B.V.	TEL: (31)297 241121	FAX: 297 273902
Italy : IWAKI Italia S.R.L.	TEL: (39)02 990 3931	FAX: 02 990 42888
Norway : IWAKI Norge AS	TEL: (47)66 81 16 60	FAX: 66 81 16 61
Spain : IWAKI Iberica Pumps, S.A.	TEL: (34)943 630030	FAX: 943 628799
Sweden : IWAKI Sverige AB	TEL: (46)8 511 72900	FAX: 8 511 72922
Switzerland : IWAKI (Schweiz) AG	TEL: (41)26 674 93 00	FAX: 26 674 93 02
U.K. : IWAKI Pumps (UK) Ltd.	TEL: (44)1743 231363	FAX: 1743 366507
U.S.A. : IWAKI America Inc.	TEL: (1)508 429 1440	FAX: 508 429 1386

ASIA / OCEANIA

Australia : IWAKI Pumps Australia Pty Ltd.	TEL: (61)2 9899 2411	FAX: 2 9899 2421
China		
Hong Kong : IWAKI Pumps Co., Ltd.	TEL: (852)2607 1168	FAX: 2607 1000
Shanghai : IWAKI Pumps (Shanghai) Co., Ltd.	TEL: (86)21 6272 7502	FAX: 21 6272 6929
Guangzhou : GFTZ IWAKI Engineering & Trading Co., Ltd.	TEL: (86)20 8435 0603	FAX: 20 8435 9181
Beijing : GFTZ Iwaki Engineering & Trading Co., Ltd. (Beijing office)	TEL: (86)10 6442 7713	FAX: 10 6442 7712
Korea : IWAKI Korea Co., Ltd.	TEL: (82)2 2630 4800	FAX: 2 2630 4801
Malaysia : IWAKI Sdn. Bhd.	TEL: (60)3 7803 8807	FAX: 3 7803 4800
Singapore : IWAKI Singapore Pte Ltd.	TEL: (65)6316 2028	FAX: 6316 3221
Indonesia : IWAKI Singapore (Indonesia Branch)	TEL: (62)21 6906606	FAX: 21 6906612
Taiwan : IWAKI Pumps Taiwan Co., Ltd.	TEL: (886)2 8227 6900	FAX: 2 8227 6818
Thailand : IWAKI (Thailand) Co., Ltd.	TEL: (66)2 322 2471	FAX: 2 322 2477
Vietnam : IWAKI Pumps Vietnam Co., Ltd.	TEL: (84)613 933456	FAX: 613 933399

()Country codes

Caution for safety use: Before use of pump, read instruction manual carefully to use the product correctly.
Actual pumps may differ from the photos. Specifications and dimensions are subject to change without prior notice. For further details please contact us.