

IWAKI
MAGNETIC
DRIVE
PUMPS

MDW



Patent

JAPAN / U.S.A. / EU / CHINA / TAIWAN

Solutions for chemical handling applications

Max. flow capacity of 300m³/hr and max. discharge head of 98m. The world's largest class fluoroplastic magnetic drive pump.

The MDW series are the largest class fluoroplastic magnetic drive pumps in the world, offering high efficiency and durability for chemical process applications. Using larger motors for even higher output, the MDW series opens up performance potential in previously unexplored areas.

Application example

- Chemical transfer between supply tanks and through chemical process equipment.
- Chemical recirculation for filtration and heat exchange applications.
- Scrubber liquid recirculation.
- Replacements for conventional sealed pumps.



MDW100

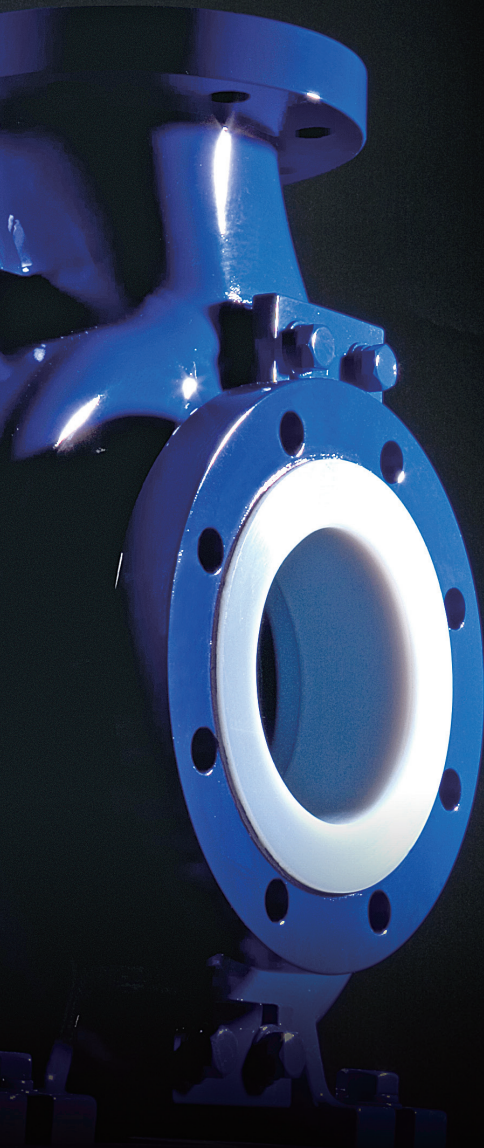

High discharge capacity, High head and high efficiency

The heavy-duty MDW is capable of a maximum discharge capacity of 300m³/hr and max. discharge head of 98m, enabling applications in previously unexplored areas with a wide range of liquid specific gravities.

Highly chemically resistant

Fluoroplastic and fine ceramic wetted parts offer high resistance to virtually every industrial chemical, irrespective of concentration.

Robust structure

Use of the high strength ductile cast iron external armour is mandatory for heavy duty chemical process applications. High casing pressure resistance is achieved with a unique rear casing design preventing stress concentration and incorporating a triple-layer structure (PAT). A special metal shaft is used on the MDW to withstand high radial forces and allow continuous extended operation even under harsh service conditions.

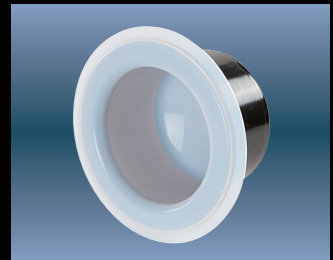

Back pullout system

The back pullout system allows easy maintenance and inspection without removing pipework. Integrated components and a sealed rear casing support structure enable motor removal safely without chemical leakage.

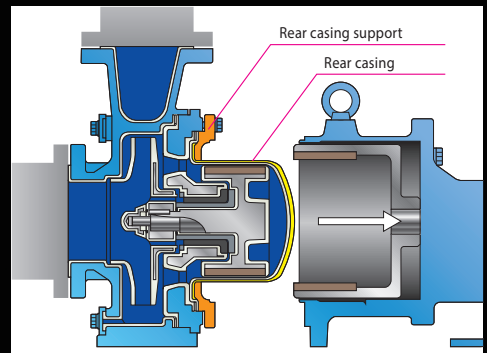

ISO compliant

The MDW is dimensionally compliant with the international standard (ISO2858, 3661) and is interchangeable with conventional sealed centrifugal pumps.

Performance curves

(Flow range of IWAKI Magnetic drive process pumps)

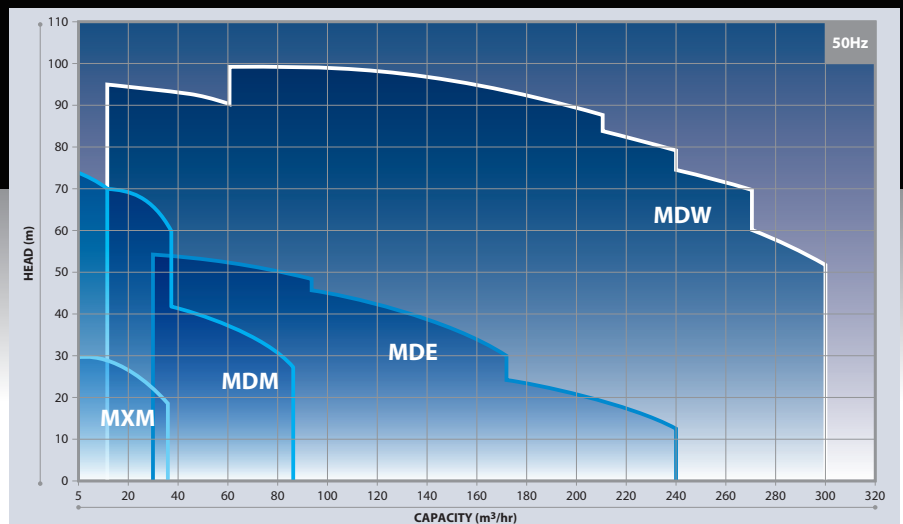

Construction

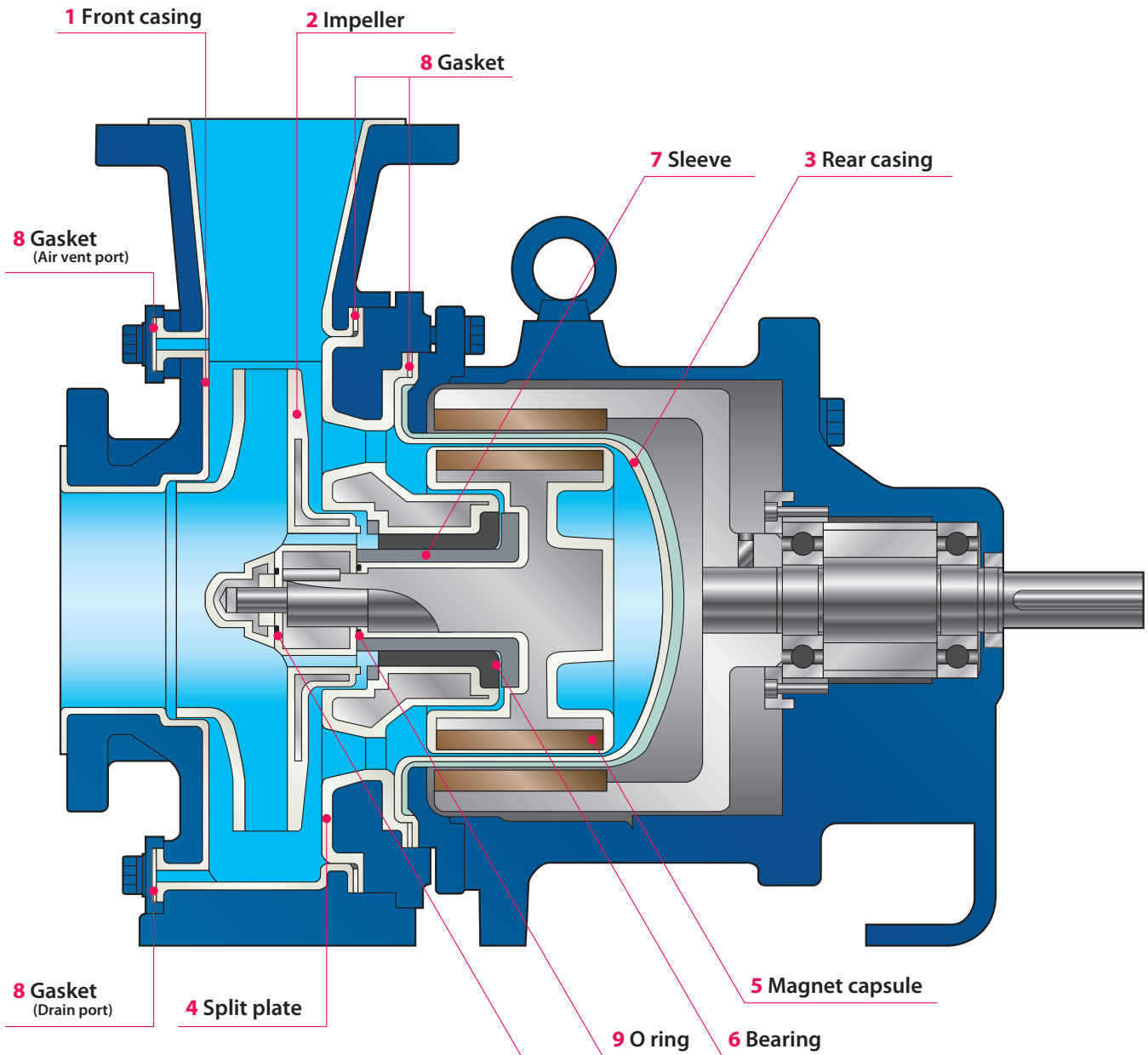

Wet-end materials

Part number	Part name	MDW50	MDW80, 100
1	Front casing	PFA	ETFE
2	Impeller	PFA	CFRETFE
3	Rear casing		PFA
4	Split plate		PFA
5	Magnet capsule		PFA
6	Bearing		SiC
7	Sleeve		SiC
8	Gasket		PTFE
9	O-ring		Kalrez®

Pump identification

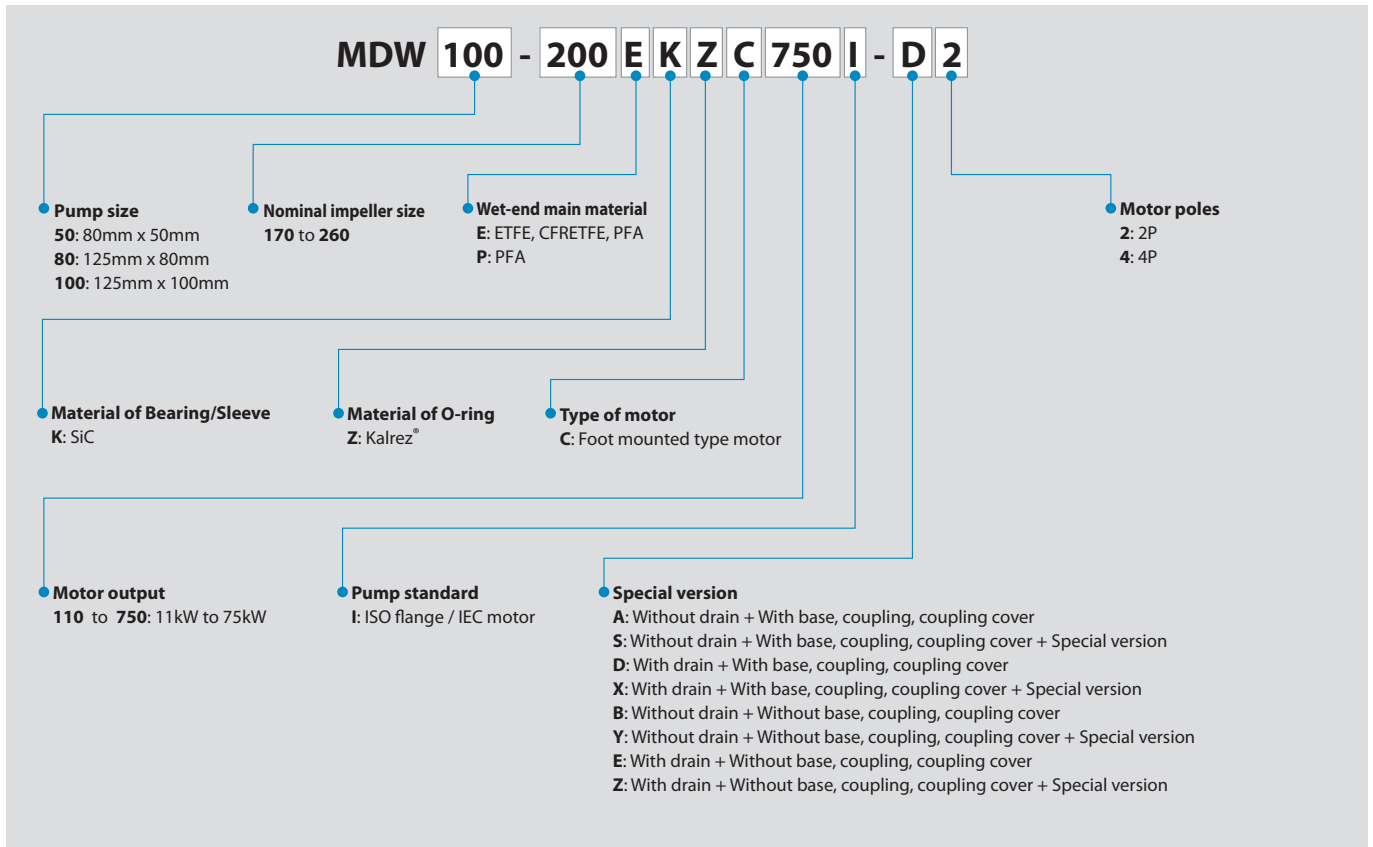

Specification

Model	Pump size Suction X Discharge	Nominal Impeller size	Capacity m ³ /hr (L/min)	Head m	Motor kW	
MDW50	80mm X 50mm	250	50 (833)	83	2P	22, 30, 37, 45, 55, 75
		260	25 (417)	21.5	4P	11, 15, 18.5, 22, 30, 37
MDW80	125mm X 80mm	250	160 (2667)	90	2P	37, 45, 55, 75
		255	80 (1333)	23	4P	11, 15, 18.5, 22, 30, 37
MDW100	125mm X 100mm	200	200 (3333)	62	2P	37, 45, 55, 75
		235	100 (1667)	21.5	4P	11, 15, 18.5, 22, 30, 37

Common specification

Temperature range of liquid handled	MDW80/100: -10 to 105°C, MDW50: -10 to 120°C
Maximum operating pressure	1.6MPa
Motor	Foot mounted type motor

Performance curves (50Hz)

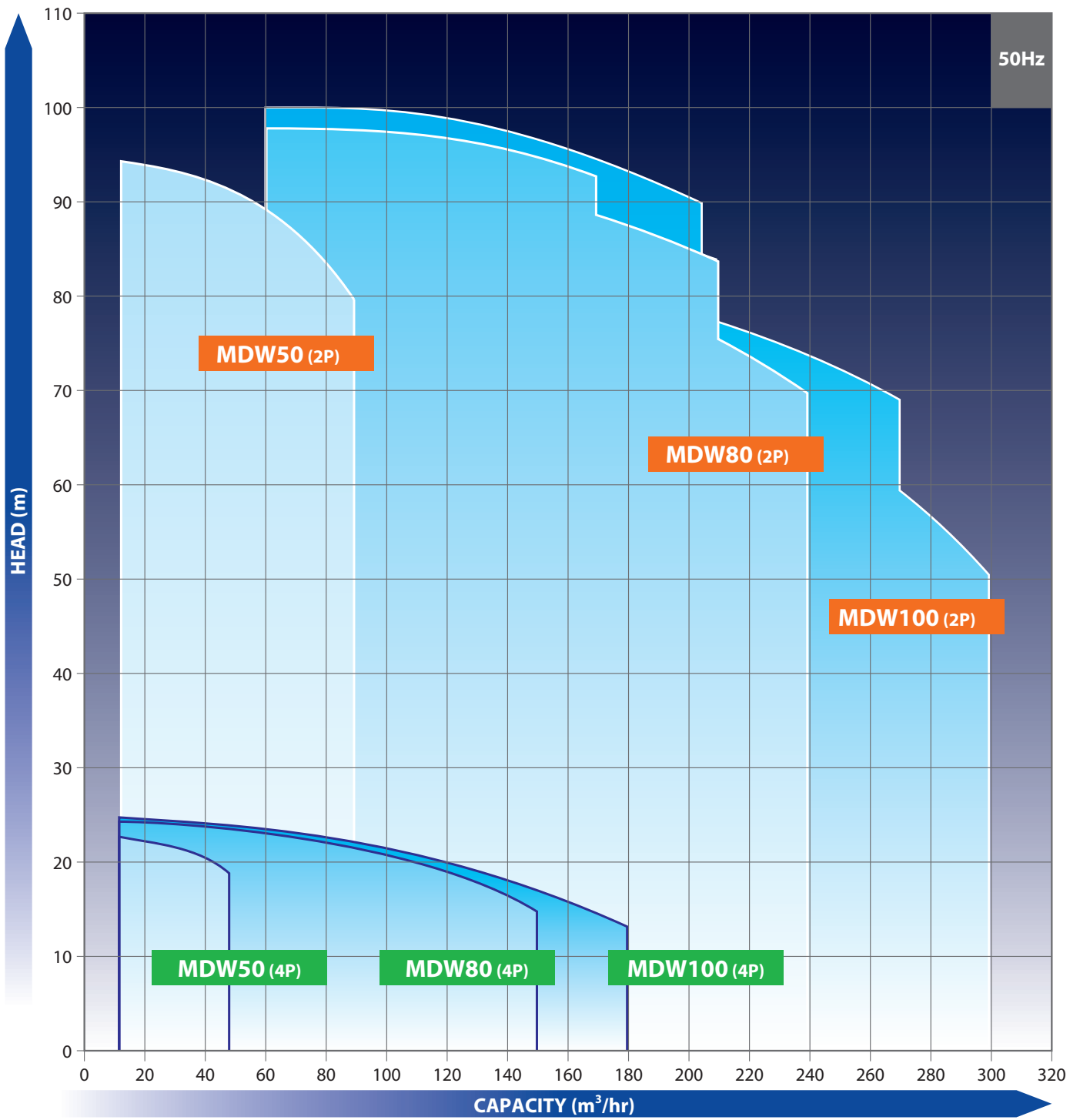

Dimension (mm)

MDW50

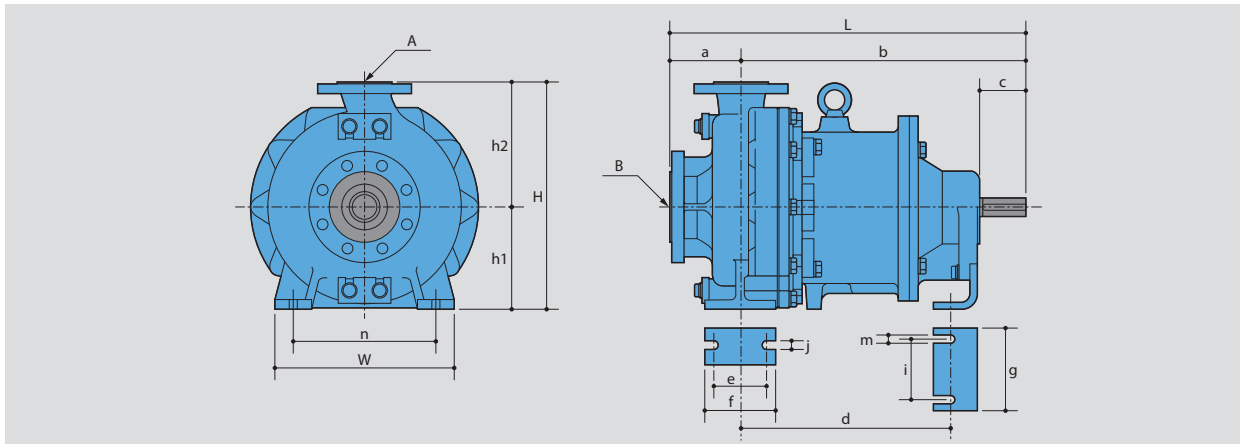

MDW80

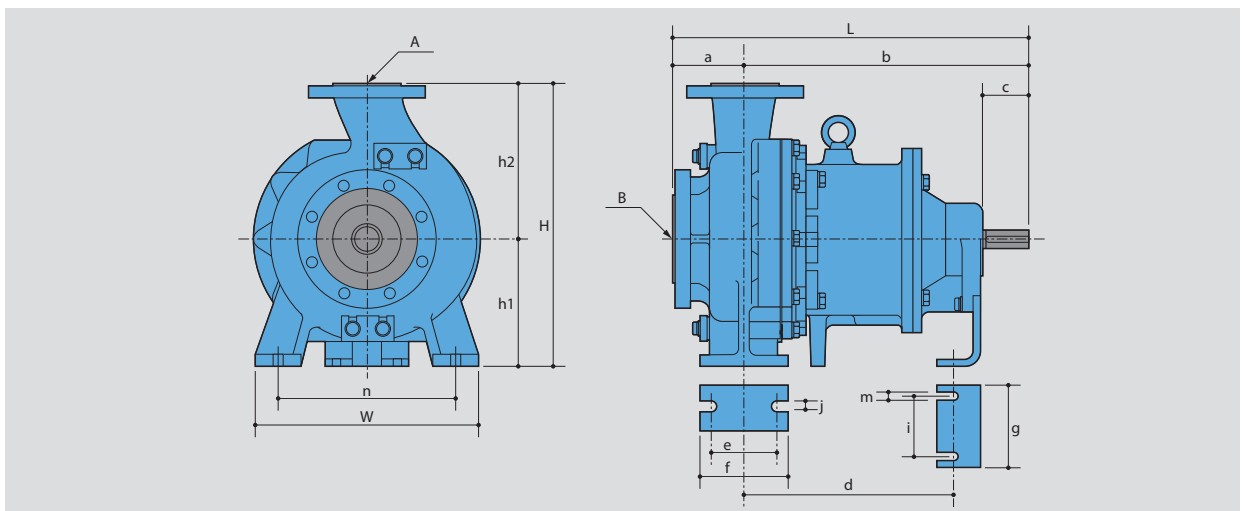

MDW100

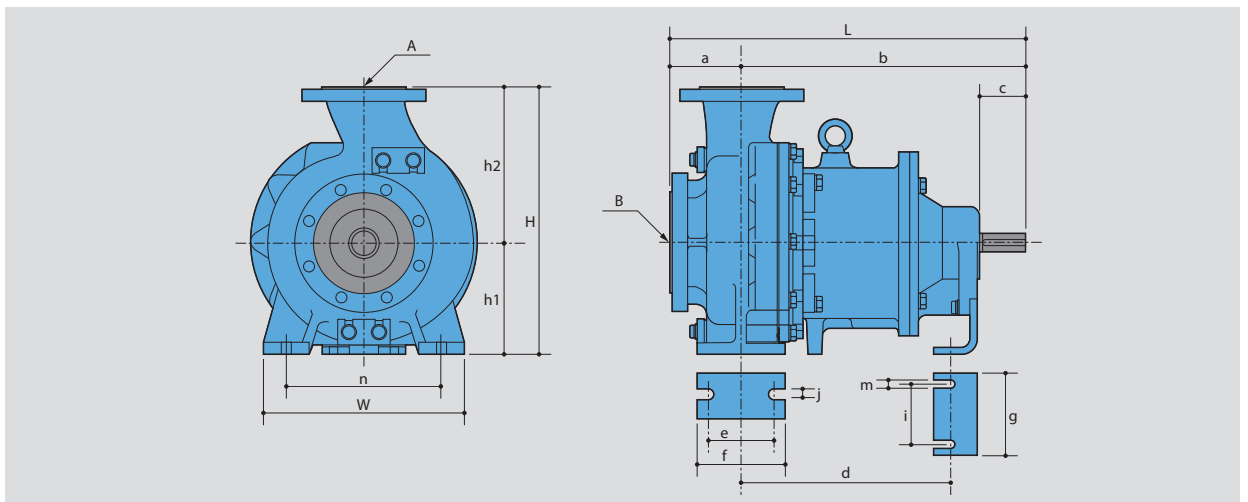

	W	H	L	A	B	a	b	c	d	e	f	g	h1	h2	i	j	n	m
MDW50	320	(405)	(625)	50mm dia.	80mm dia.	125	500	80	370	95	125	150	180	225	110	14	250	14
MDW80	400	(505)	(625)	80mm dia.	125mm dia.	125	500	80	370	120	160	150	225	280	110	18	315	14
MDW100	360	(480)	(625)	100mm dia.	125mm dia.	125	500	80	370	120	160	150	200	280	110	18	280	14

IWAKI Process magnetic drive pump series

MDE SERIES

The most reliable, large-sized magnetic drive pump designed for process use

Specifications

- Max. discharge capacity: 4.0 m³/min
- Max. head: 55m
- Main materials: ETFE, PFA, SiC
- Liquid temp. range: 0 to 100°C

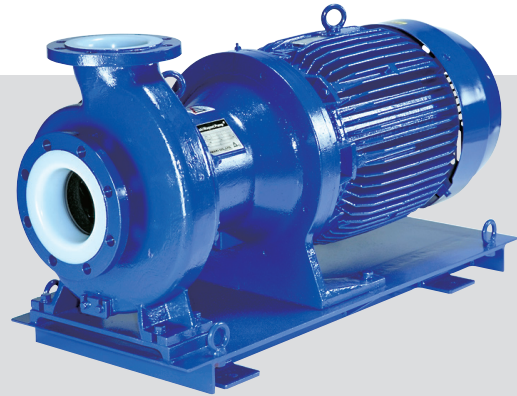

MDM SERIES

Magnetic drive process pumps with dry running capability

Specifications

- Max. discharge capacity: 1.4m³/min
- Max. head: 74m
- Main materials: CFRETFE/PFA
- Liquid temp. range: -20 to 105°C(CFRETFE), -20 to 150°C(PFA)

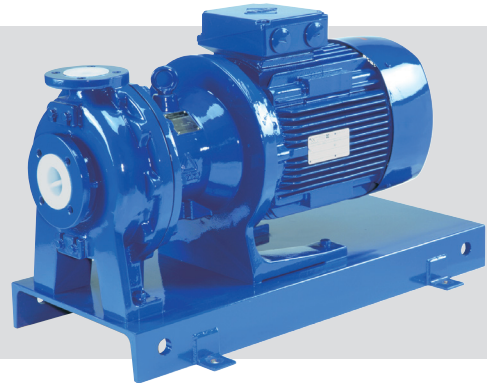

MXM SERIES

Magnetic drive pumps with an excellent balance of features and performance

Specifications

- Max. discharge capacity: 0.6m³/min
- Max. head: 29m
- Main materials: CFRETFE
- Liquid temp. range: -10 to 105°C



Optional accessories

Iwaki pump protector DRN series

Detects unusual pump operating conditions including dry-running and overload

The DRN model protects equipment (including pumps) from damage!
Minimizes production downtime.
Identifies possible causes of alarms so they can be investigated and addressed.

Multiple Input	Two analog, one digital, one temperature input and one current input
Easy operation	Equipped with EASY setup mode to remember the operation status and set the lower/upper limit values, as well as AUTO setup mode
Bar graph	Visible indication of current operating status
Logging capability	Data log feature for preventative maintenance scheduling
Communication	RS485 external communication capability



Specifications

Model	DRN-01	DRN-02
Amperometric range	0.5-30.00A	5.0-200.0A
Unit's source voltage	AC100-240V 50/60Hz 10VA	
Operating temperature	0-40°C	
Operating humidity	35-85%RH	



<https://www.iwaki.de>

IWAKI Europe GmbH, Siemensring 115, 47877 Willich, Germany
TEL: +49 2154 9254 10 FAX: +49 2154 9254 48 E-Mail: sales@iwaki.de

⚠ Caution for safety use: Before use of pump, read instruction manual carefully to use the product correctly. Actual pumps may differ from the photos. Specifications and dimensions are subject to change without prior notice. For further details please contact us.

⚠ Legal attention related to export. Our products and/or parts of products fall in the category of goods contained in control list of international regime for export control. Please be reminded that export license could be required when products are exported due to export control regulations of countries. The posting and copying from this catalogue without permission is not accepted firmly.